



INTRODUCING

Viva

MULTISEATER

BUILD WITH CONFIDENCE





Specification :

- Seat/Back** - Plastic injection moulded seat and back with good textured finish and Good balance of stiffness & impact resistance incorporated virgin material
- Armrest/Legs** - Plastic Injection moulded with textured finish high rigidity polyamide material to bear the desirable loads
- Centrebeam** - MS square tube of 1.6mm thickness Processed & furnished with powder coating.

**Available Colors in*
LIGHT GRAY | ROYAL BLUE | DARK GRAY



VIVA SINGLE SEATER



VIVA TWO SEATER



VIVA THREE SEATER



VIVA FOUR SEATER



VIVA SIX SEATER

VIVA MULTI SEATER PLASTIC SOFA DIMENSIONS

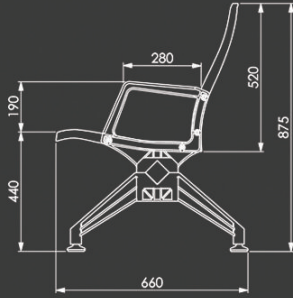
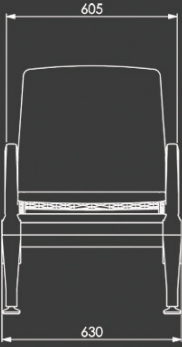

VIVA MULTISEATER - 1 SEATER
WEIGHT - 10.82 KG

VIVA MULTISEATER - 2 SEATER
WEIGHT - 16.88 KG

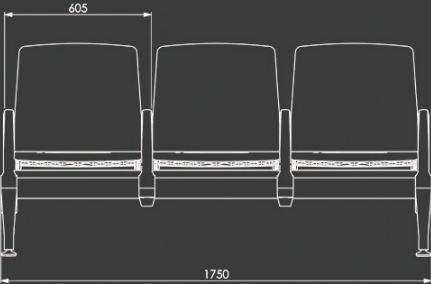
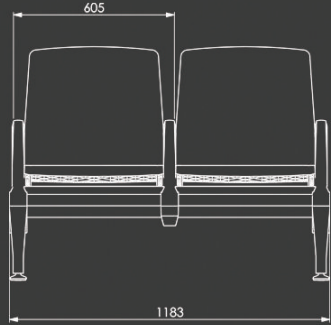

VIVA MULTISEATER - 3 SEATER
WEIGHT - 23.72 KG

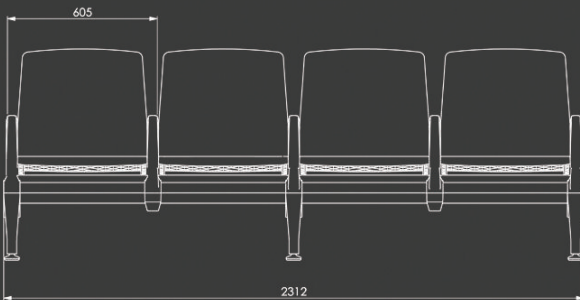

VIVA MULTISEATER - 4 SEATER
WEIGHT - 30.72 KG

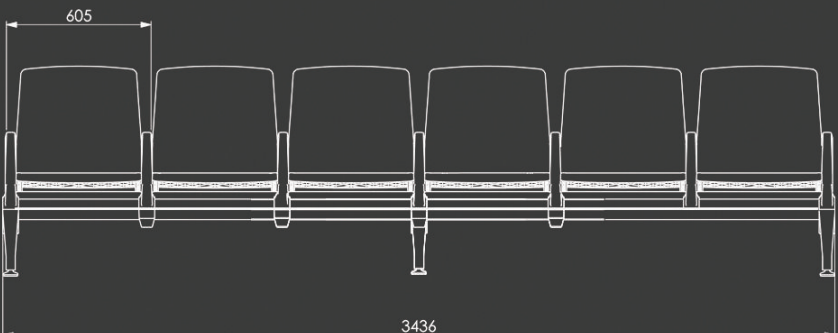

VIVA MULTISEATER - 6 SEATER
WEIGHT - 43.37 KG

* All dimensions are in MM

* WARRANTY APPLICABLE ONLY FOR MANUFACTURING DEFECTS



TEMPERATURE RESISTANCE



AVAILABLE FOR OUTDOOR APPLICATION ALSO (CHARGES MAY VARY FOR UV PROTECTOR)



RUST PROOF (SEAT , BACK , ARMS & LEGS)



EASY TO INSTALL



ANTI - STATIC



WASHABLE



DURABLE



RECYCLABLE



MADE IN INDIA



VIVA MULTI SEATER PLASTIC SOFA 3 SEATER ASSEMBLY INSTRUCTION



VIVA MULTI SEATER CHILD PARTS & ACCESSORIES

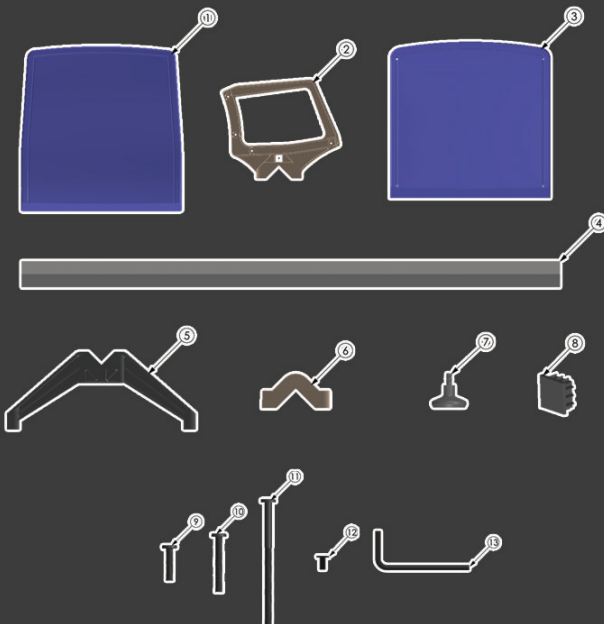

VIVA MULTI SEATER 3S ASSEMBLY

STEP 1A:

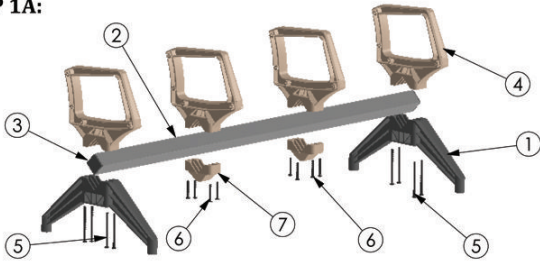

STEP 1B:

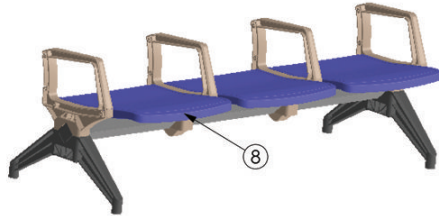

STEP 1B:

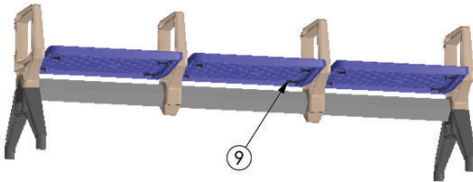

STEP 1C:



STEP 1C:

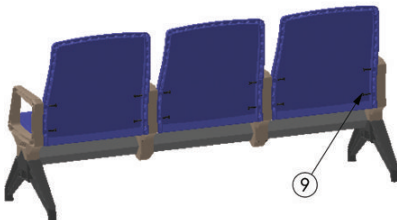

STEP 2A:



VIVA MULTI SEATER 3S ASSEMBLY

STEP 2B:



STEP 2C:



STEP 1A:

1. Place the leg assembly on the extreme ends of centerbeam.
2. Place the center beam assembly above the legs.
3. Place the handle above the leg use Flat head M8 x 135mm bolt in loose condition.
4. Place the handle above centerbeam & use the handle holder to clamp the inbetween handles & use M8 x 65mm bolt in loose condition.

STEP 1B: Place the seat between the handle & use M8 x 35mm bolt to tighten the seat to the handle (for required quantity).

STEP 1C: Place the back between the handle & use M8 x 35mm bolt to tighten the back to the handle (for required quantity).

After done required alignments should tighten the all bolts.

STEP 2A: Place the insert cap to the handle insert outside area and ensure them inserts hide from the handle.

STEP 2B: Assemble the leveller in the legs & adjust as per your requirement.

STEP 2C: Ensure the all bolts to be tighten & see the appearance if everything is perfect now Axis multiseater is ready to use.

Viva
MULTISEATER



ADDRESS :

NO: 36/4, BALFOUR ROAD, KILPAUK, CHENNAI-10
PH.NO : +91 98417 98417 | WEBSITE : WWW.MBMINDIA.CO.IN
E-MAIL : SALES@MBMINDIA.CO.IN

BANGALORE BRANCH

NO,275/8, NEW TIMBER YARD LAYOUT,
INSIDE NAK KALYANA MANDAPPAM,
MYSORE ROAD, BANGALORE - 560026.
+91 94480 51246 / +91 94480 53689 /
+91 95386 77428

HYDERABAD BRANCH

CENTRAL WAREHOUSING CORPORATION,
GODOWN NO. B-3, BEHIND - GANDHI BHAVAN,
NAMPALLY, HYDERABAD - 500001.
+91 8500 364 068 / +91 8500 274 068

MUMBAI

SHOP NO. A/4, FIRST FLOOR, MAHAVIR ESTATE,
SAKINAKA, ANDHERI GHATKOPAR LINK ROAD,
BEHIND TILAK NAGAR GATE, SAKINAKA,
MUMBAI-400072. PH :- +91 9004472306

DELHI BRANCH

KHASRA NO. 51/6, VILLAGE ALIPUR,
LANDMARK SPLASH WATER PARK,
DELHI - 110036.
+91 93126 72007 / +91 82876 04060